



**SPECIALLY DESIGNED
TO FIT EASILY INTO
Your Home ”**

- Minimal Construction Work
- No Machine-Room Required
- Small Footprint
- Fast Installation
- Packed With Safety Features
- Modern Design & Quiet
- Minimal Maintenance
- Economical To Use
- Self Supporting Structure
- Compact Drive System
- Wheelchair Accessible (Optional)
- Outdoors & Thru Application (Optional)

IN CASE OF POWER OUTAGE WHILE IN THE LIFT,
The cabin will gently descend to the lower level,
and let the passenger exit the lift safely.



CONTACTS



INSTAGRAM



HOME LIFTS

www.eltouny.net



General Specification

Drive	Floors	Travel	Pit	Headroom	Power	Standard Color
Roped Drum Motor	2 (G-1)	Up to 4m	No Pit Needed	2700 mm	240 V / 1Ph / 50Hz	Off White (7038)
<ul style="list-style-type: none"> Full Height Door or Half-Height Door with safety Light Curtain 		<ul style="list-style-type: none"> Indoor 	<ul style="list-style-type: none"> 2 Remote Control 		<ul style="list-style-type: none"> Full Imported From UK 	



STILTZ DUO	<ul style="list-style-type: none"> Load: 160 kg
	<ul style="list-style-type: none"> External Dimension: 1047x810 mm
	<ul style="list-style-type: none"> Optional: ThruCar (2Doors)

STILTZ TRIO	<ul style="list-style-type: none"> Load: 220 kg
	<ul style="list-style-type: none"> External Dimension: 1047x1280 mm
	<ul style="list-style-type: none"> Wheelchair Accessible

Stiltz Safety Features

- Stiltz Lift will detect objects above or below the lift, and will stop immediately should something or someone stand on the lift car lid upstairs or below the lift as it descends
- Battery Back Up System
- Top & Bottom Safety Pans
- Weight Limit Sensors
- Out Of Balance Sensors
- Fall Arrest Mechanism
- Key Switch Operation
- Hold-To-Run Controls
- Emergency Stop Button
- One Year Warranty
- Telephone
- Light Curtain

SLIM HOME LIFT

General Specification

Drive	Roped Drum Motor
Floors	2 (G-1)
Travel	Up to 4m
Application	Indoors
Pit	130 mm
Headroom	2700 mm
Power	240 V single phase
Load	Up to 160 kg
External Dimension	1150 mm x 1100 mm
Cabin Dimension	950 mm x 850 mm
Fit	Wheelchair Accessible

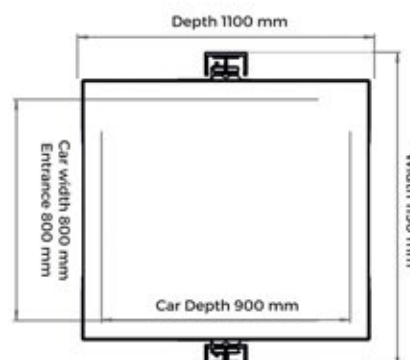

ECO HOME LIFT

General Specification

Drive	Floors	Travel	Pit	Headroom	Speed	Power
Roped Winding Drum	Up to 3 Floor (G-1-2)	Up to 7m	130 mm	3000 mm	0.3 m/s	220V single Phase or 3 Phases 380V

• **Standard Colors:** Black - White - Beige - Gray

• **Indoors Only**

• **Customized**

ECO 115 Round

- Painted Stainless Steel & Polycarbonate
- Load: 160 kg
- External Dimension: 1200 mm
- Cabin Diameter: 900 mm

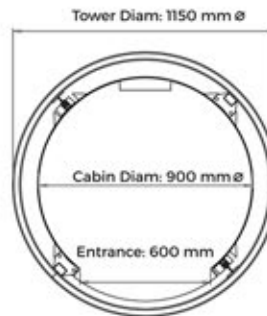

ECO 130 Round

- Painted Stainless Steel & Polycarbonate
- Load: 250 kg
- External Dimension: 1350 mm
- Cabin Diameter: 1050 mm

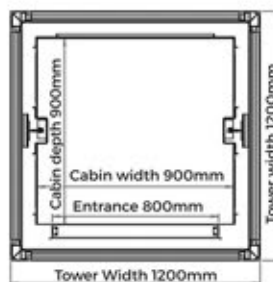
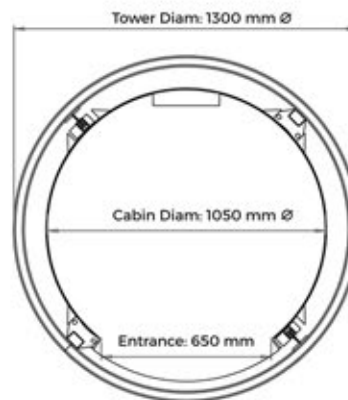

ECO+ 120 Square

- Aluminium Shaft & Glass
- Load: 160 kg
- External Dimension: 1250 mm x 1250 mm
- Cabin Dimension: 950 mm x 950 mm

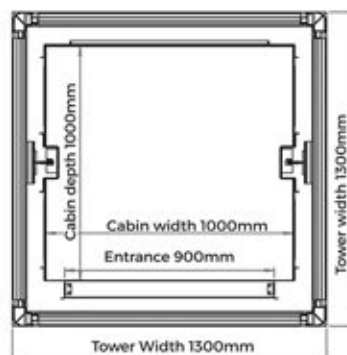

ECO+ 130 Square

- Aluminium Shaft & Glass
- Load: 250 kg
- External Dimension: 1350 mm x 1350 mm
- Cabin Dimension: 1050 mm x 1050 mm

MINI HOME LIFT (Heavy Duty)

General Specification

Drive	Floors	Travel	Headroom	Power
Gearless (German/Italian)	Up to 4 Floor (C-1-2-3)	Up to 10m	2800 mm	3 Phases 380V

• **Standard Colors:** Black - White - Beige - Gray

• **Customizable**

MINI 120 Round

- Painted Stainless Steel & Polycarbonate
- **External Dimension:** 1250 mm
- **Cabin Diameter:** 1000 mm x 850 mm
- **Pit:** 120 mm
- **Indoors Only**

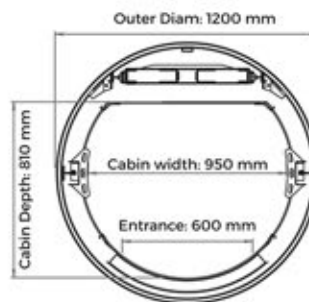

MINI 140 Round

- Painted Stainless Steel & Polycarbonate
- **External Dimension:** 1450 mm
- **Cabin Diameter:** 1200 mm x 1050 mm
- **Pit:** 120 mm
- **Indoors Only**

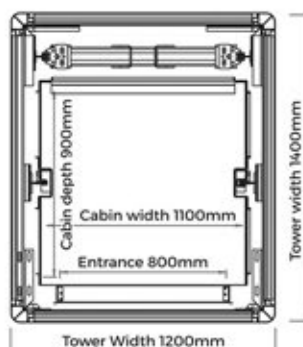
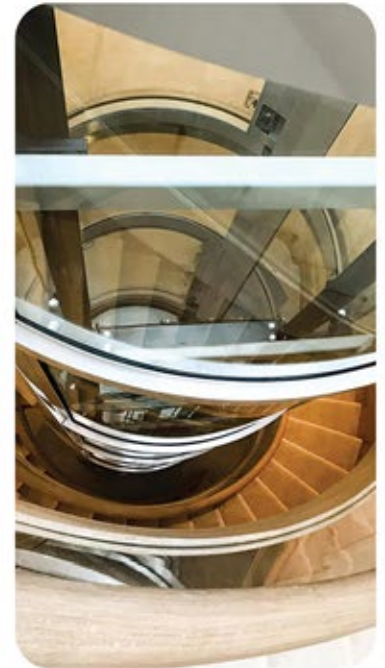
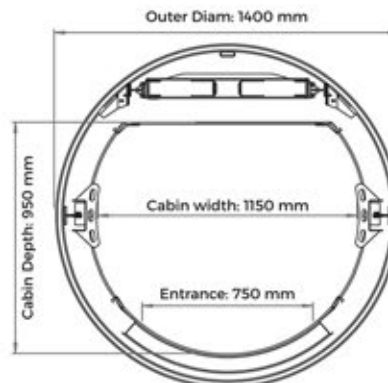

MINI+ Compact Square

- **Aluminium Shaft & Glass**
- **Load:** 160 kg
- **External Dimension:** 1200 mm x 1400 mm
- **Cabin Dimension:** 800 mm x 800 mm
- **Pit:** 200 mm
- **Indoors / Outdoors**

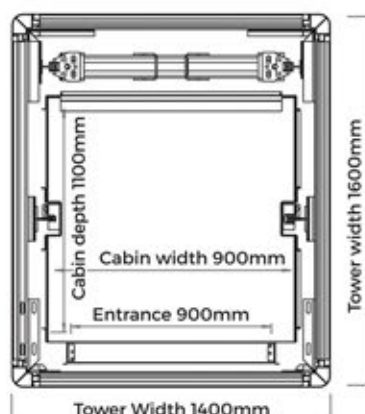

MINI+ Elite Square

- **Aluminium Shaft & Glass**
- **Load:** 250 kg
- **External Dimension:** 1400 mm x 1600 mm
- **Cabin Dimension:** 1000 mm x 1000 mm
- **Pit:** 200 mm
- **Indoors / Outdoors**

NANO (Heavy Duty)

General Specification

Drive	Gearless (German/Italian)
Floors	Up to 4 Floor (G-1-2-3)
Travel	Up to 10m Travel
Optional	Up to 3 Doors
Pit	300 mm
Headroom	2800 mm
Power	3 Phases 380V
Load	Up to 360 kg
Dimension	Customizable
Interiors & Exteriors	Customizable
Optional	Wheelchair Accessible
Optional	Outdoors Application

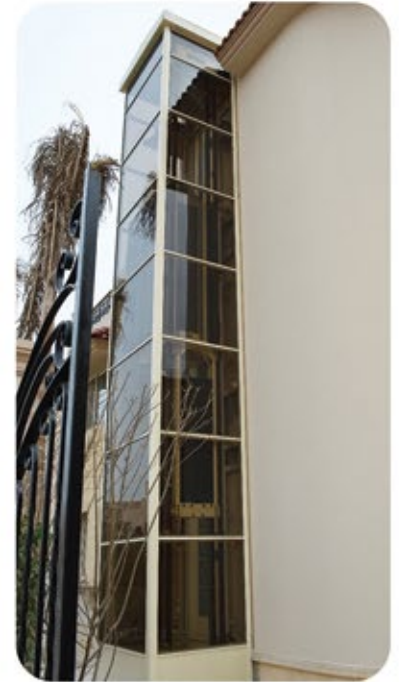
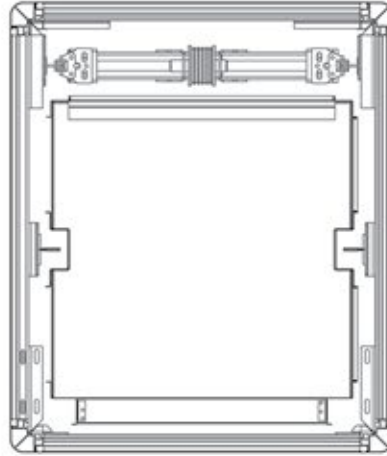

ACORN



ACORN
STAIRLIFTS

General Specification

- **Drive:** Rack & Pinion
- **Safety:** 5 Sensors
- **Remote Controls:** 2
- **Power:** 220V - Single Phase
- **Fit to the staircase not the wall**
- **Chair:** 980 mm x 590 mm
- **Depth from wall:** 270 mm
- **Overall Height:** 980 mm
- **Fully Imported From UK**
- **Backup:** Battery
- **Folding Foot Rest**
- **Overall Width:** 605 mm



STRAIGHT STAIRLIFT

- **Load Standard:** 120 kg
- **Load Heavy duty:** 160 kg
- **Max. Travel:** 10 m
- **Indoors / Outdoors**

CURVED STAIRLIFT

- **Load:** 120 kg
- **Max. Travel:** 30 m
- **Indoors Only**

Brand	Model	Drive	Load	Travel	Floors	Pit	Headroom	Structural Dimension	Cabin Dimension	Wheel-chair	Outdoors	Power	Customizable
STILTZ	STILTZ DUO	Roped Drum Motor	170 Kg	Up to 4 m	2 (G-1)	—	2700 mm	1040 x 760 mm	790 x 720 mm	—	—	220 V / Single Phase	—
STILTZ	STILTZ TRIO	Roped Drum Motor	220 Kg	Up to 4 m	2 (G-1)	—	2700 mm	1040 x 1378 mm	816 x 1237 mm	Yes	—	220 V / Single Phase	—
SLIM	SLIM X	Roped Drum Motor	160 Kg	Up to 4 m	2 (G-1)	—	2700 mm	1150 x 1100 mm	950 x 850 mm	Yes	—	220 V / Single Phase	Yes
ECO	ECO115 Round	Roped Dual Winding Drum	160 Kg	7 m	3 Floors (G-1-2)	130 mm	3000 mm	1200 mm Ø	900 mm Ø	—	—	220 V / Single Phase or 380 V / 3 Phases	Yes
ECO	ECO130 Round	Roped Dual Winding Drum	250 Kg	7 m	3 Floors (G-1-2)	130 mm	3000 mm	1350 mm Ø	1050 mm Ø	—	—	220 V / Single Phase or 380 V / 3 Phases	Yes
ECO+	ECO+ 120 Squared	Roped Dual Winding Drum	160 Kg	7 m	3 Floors (G-1-2)	130 mm	3000 mm	1250 x 1250 mm	900 x 900 mm	—	—	220 V / Single Phase or 380 V / 3 Phases	Yes
ECO+	ECO+ 130 Squared	Roped Dual Winding Drum	250 Kg	7 m	3 Floors (G-1-2)	130 mm	3000 mm	1350 x 1350 mm	1000 x 1000 mm	—	—	220 V / Single Phase or 380 V / 3 Phases	Yes
MINI	MINI 120 Round	Gearless	240 Kg	10 m	4 Floors (G-1-2-3)	120 mm	2800 mm	1250 mm Ø	950 x 810 mm	—	—	380 V / 3 Phases	Yes
MINI	MINI 140 Round	Gearless	300 Kg	10 m	4 Floors (G-1-2-3)	120 mm	2800 mm	1450 mm Ø	1150 x 950 mm	—	—	380 V / 3 Phases	Yes
MINI+	MINI+ Compact	Gearless	240 Kg	10 m	4 Floors (G-1-2-3)	200 mm	2800 mm	1200 x 1400 mm	900 x 900 mm	—	Optional	380 V / 3 Phases	Yes
MINI+	MINI+ Elite	Gearless	300 Kg	10 m	4 Floors (G-1-2-3)	200 mm	2800 mm	1400 x 1600 mm	1100 x 1100 mm	—	Optional	380 V / 3 Phases	Yes
NANO	NANO	Gearless	630 Kg	10 m	4 Floors (G-1-2-3)	300 mm	2800 mm	Customizable	Customizable	Optional	Optional	380 V / 3 Phases	Yes

• “+” = Square

LAYERS OF SAFETY

BATTERY BACKUP UPS

In the event of power failure, the elevator cabin automatically descends to the lower level.

OVERLOAD SENSOR

When the car is overloaded, the lift won't move and will give a sign on the COP.

OVERSPEED GOVERNOR

It will stop the lift if it runs beyond the prescribed speed.

SAFETY BREAKS

Even if all the cables snapped, the lift wouldn't fall to the bottom floor.

The breaks will lock in place whenever the elevators starts to fall faster than an allowed amount.

MAGNETIC DOOR LOCK SWITCH

To ensure that the door opens only if the car is available & the elevator isn't in use.

PHOTOSELL SENSORS

It will force the lift to stop immediately, when passengers or objects approach the exit of the lift while in use.

CONTACT US

+2 0100 030 7719

+2 0100 6600 988

+2 0111 210 8049

eltouny@eltouny.net

www.eltouny.net

3rd Industrial Area, 7/14 St.,
6th October, Giza, Egypt