

PL / CO	600	650	700	750	800	850	900	1000	1100	1200
A	1000	1050	1200	1250	1300	1350	1400	1500	1600	2000
C	1250	1350	1450	1550	1650	1750	1850	2050	2250	2450
O	1200	1250	1400	1450	1500	1550	1600	1700	1800	2200
E	320	345	370	395	420	445	470	520	570	620
F	4	4	5	6	6	7	7	8	9	13
PESO / WEIGHT (kg)	72	78	84	90	96	101	107	119	131	143

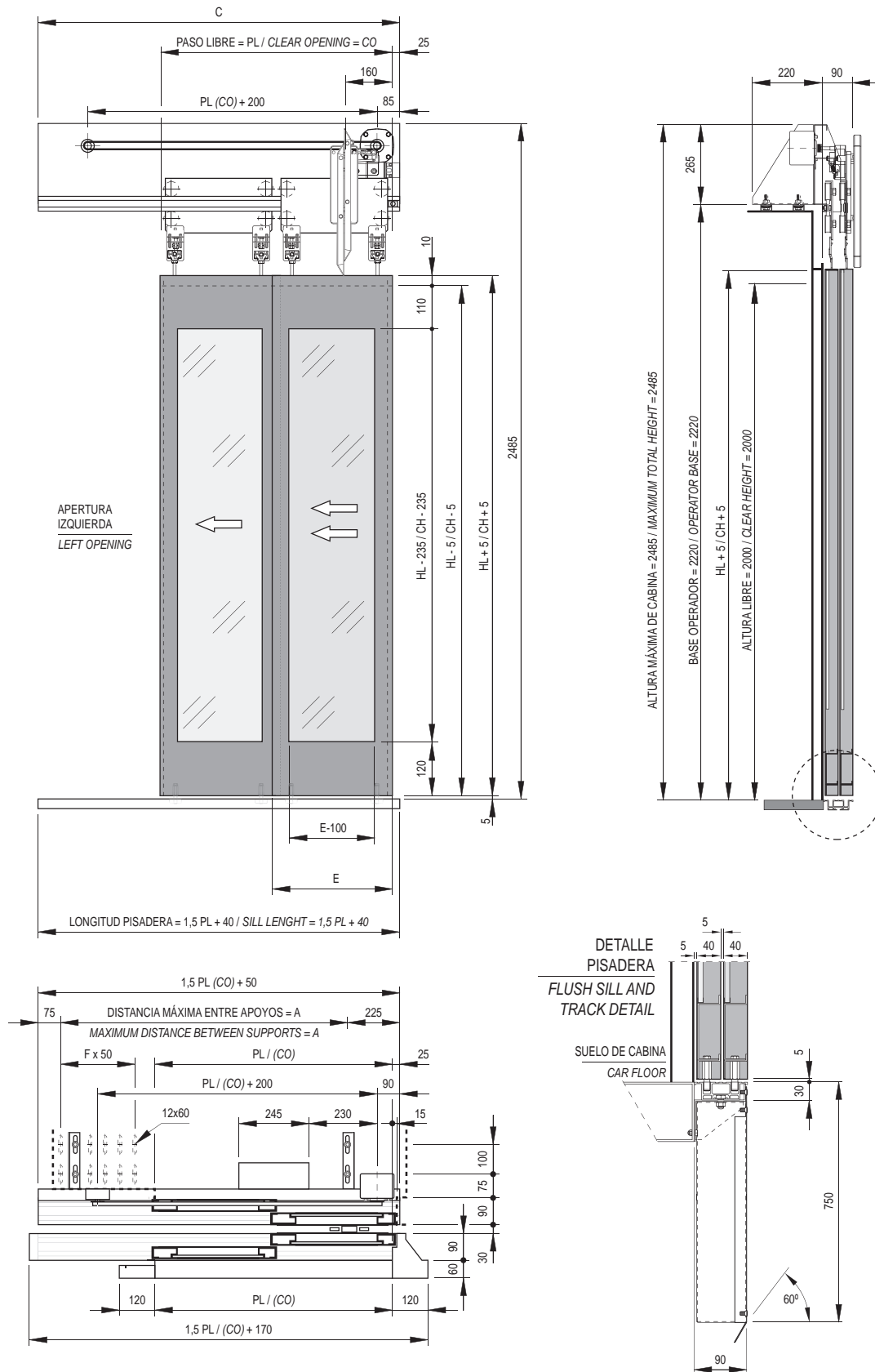

PL / CO	600	650	700	750	800	850	900	1000	1100	1200
A	650	725	800	875	950	1025	1100	1250	1400	1550
C	950	1025	1100	1175	1250	1325	1400	1550	1700	1850
E	320	345	370	395	420	445	470	520	570	620
F	4	4	5	5	6	6	6	7	8	8
PESO / WEIGHT (kg)	72	78	84	90	97	103	109	121	133	145

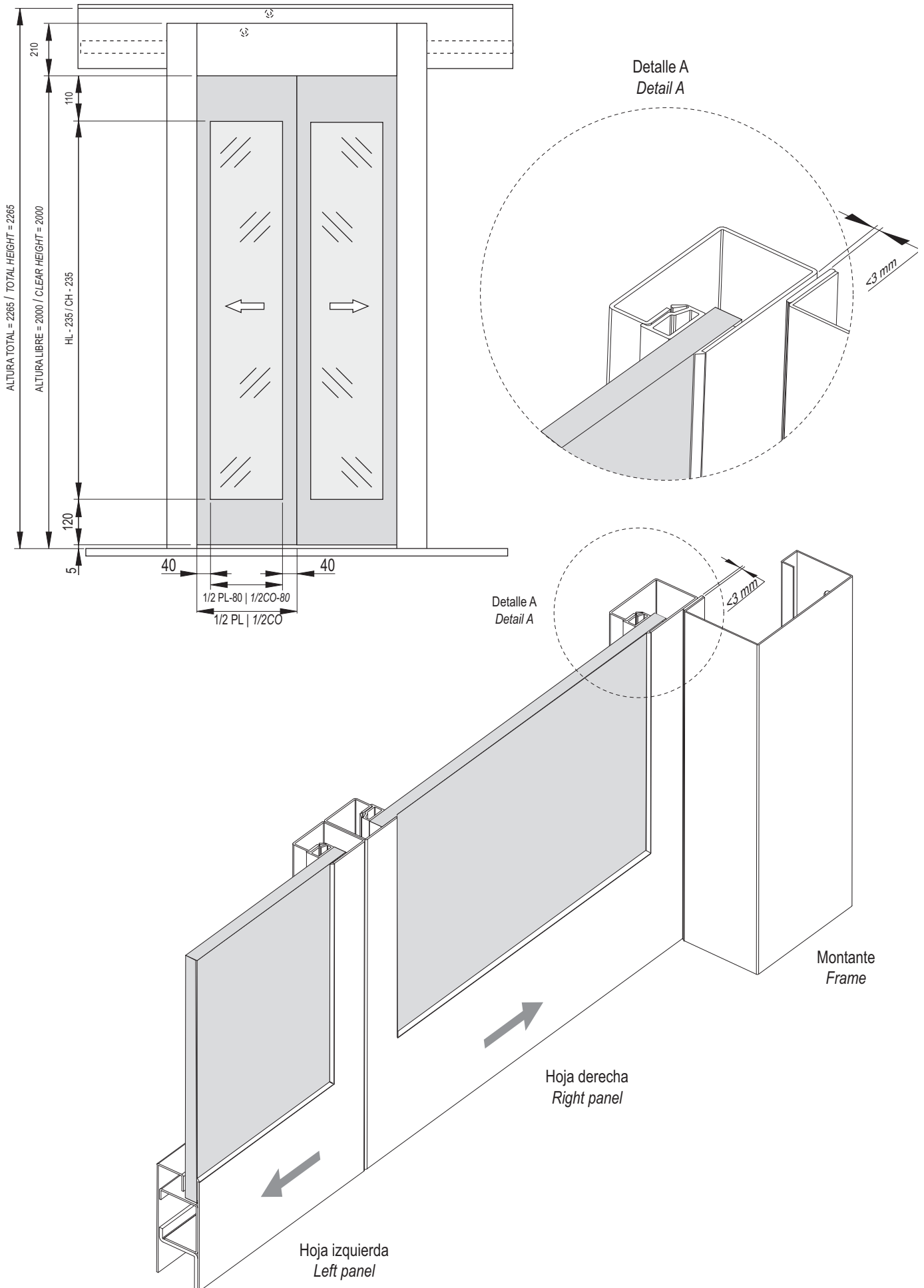

9.18.

DETALLE DE HOJAS « GRAN MIRILLA » DETAIL OF « BIG VISION » PANEL

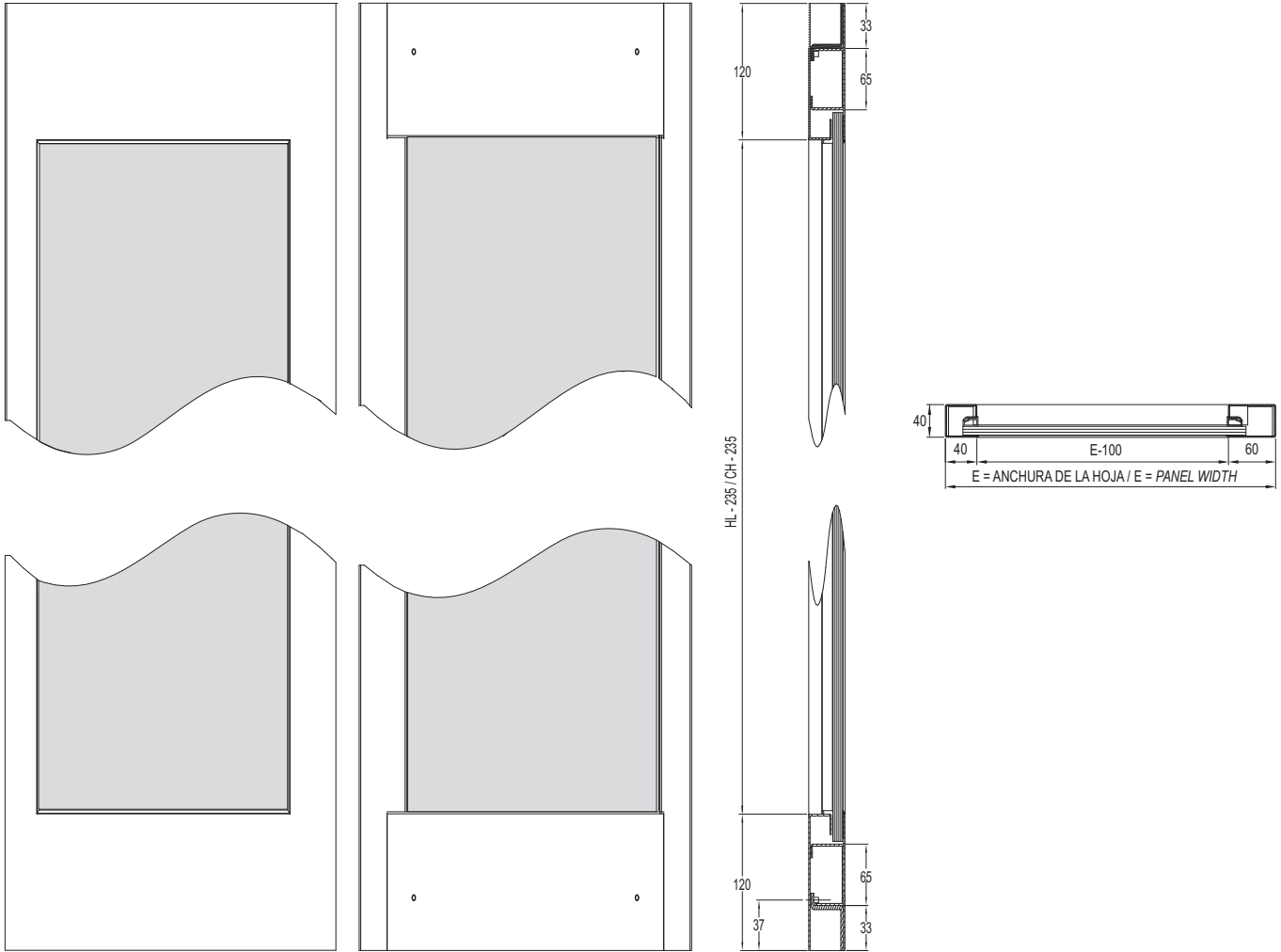

Detalle A
Detalle A

