

PL / CO	600	650	700	750	800	850	900	1000	1100	1200
A	1000	1050	1200	1250	1300	1350	1400	1500	1600	2000
C	1250	1350	1450	1550	1650	1750	1850	2050	2250	2450
O	1200	1250	1400	1450	1500	1550	1600	1700	1800	2200
E	320	345	370	395	420	445	470	520	570	620
F	4	4	5	6	6	7	7	8	9	13
PESO / WEIGHT (kg)	88'13	95'46	102'81	110'16	117'50	124'84	132'19	146'88	161'56	176'25

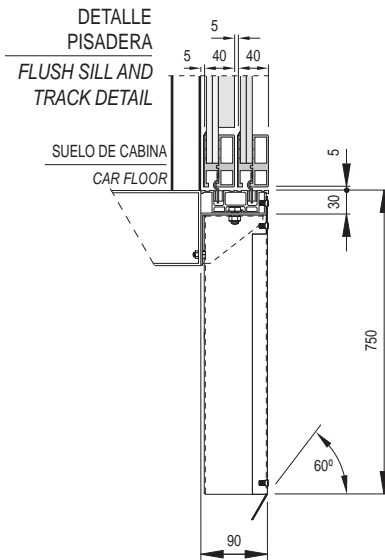

PL / CO	600	650	700	750	800	850	900	1000	1100	1200
A	650	725	800	875	950	1025	1100	1250	1400	1550
C	950	1025	1100	1175	1250	1325	1400	1550	1700	1850
E	320	345	370	395	420	445	470	520	570	620
F	4	4	5	5	6	6	6	7	8	8
PESO / WEIGHT (kg)	102'75	109'44	116'13	122'81	129'50	136'19	142'88	156'25	169'63	183'00

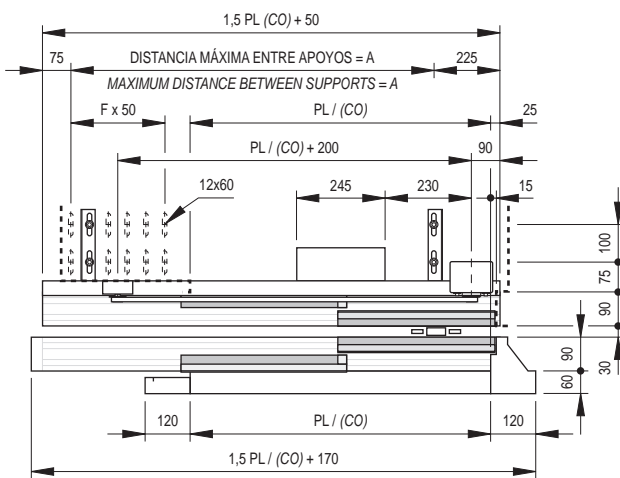
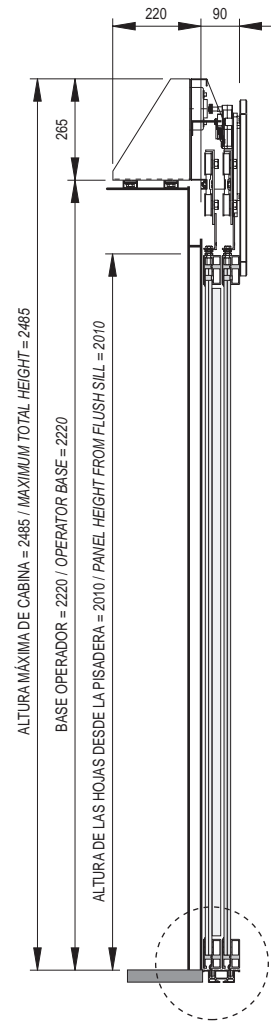
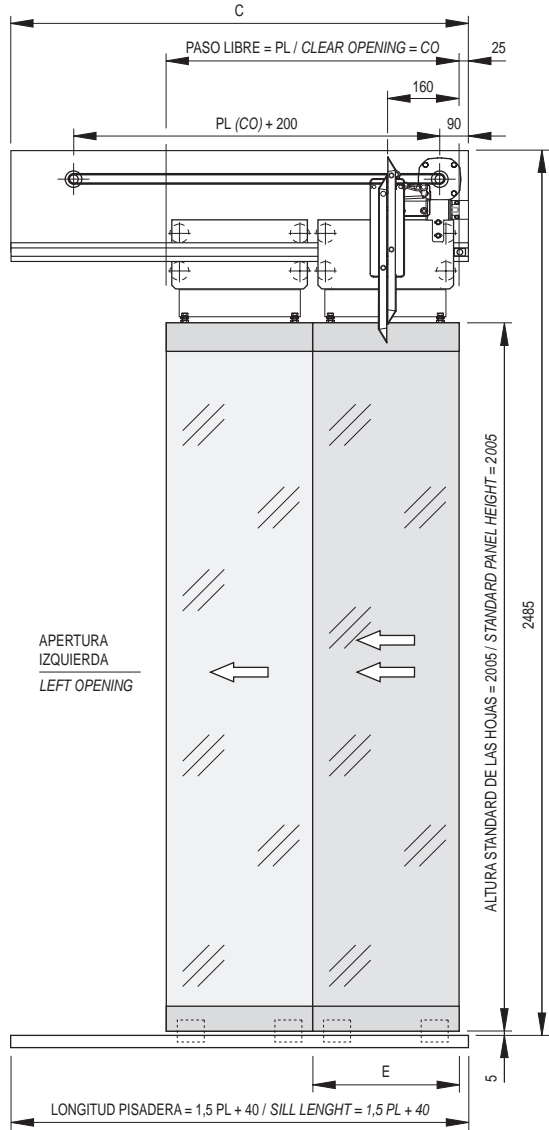
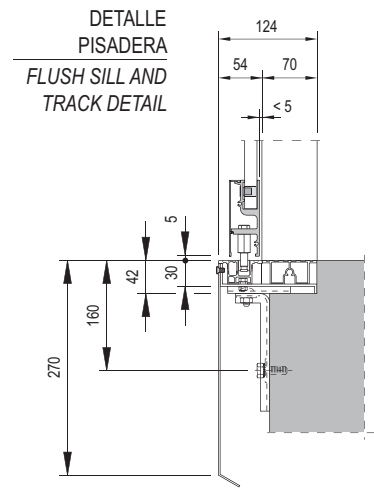
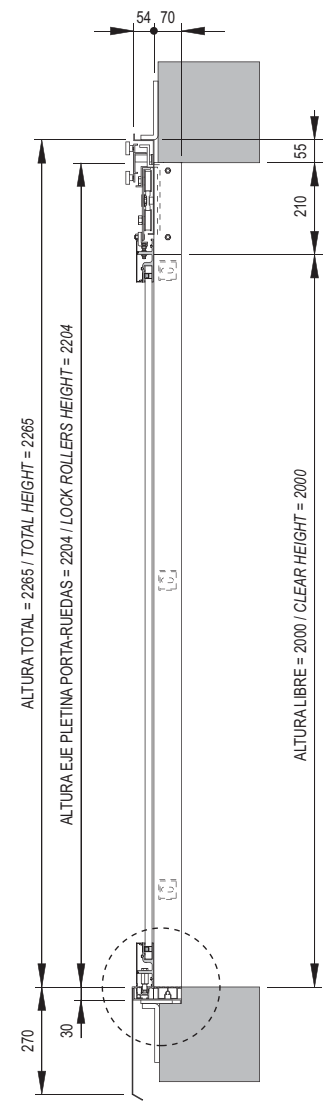
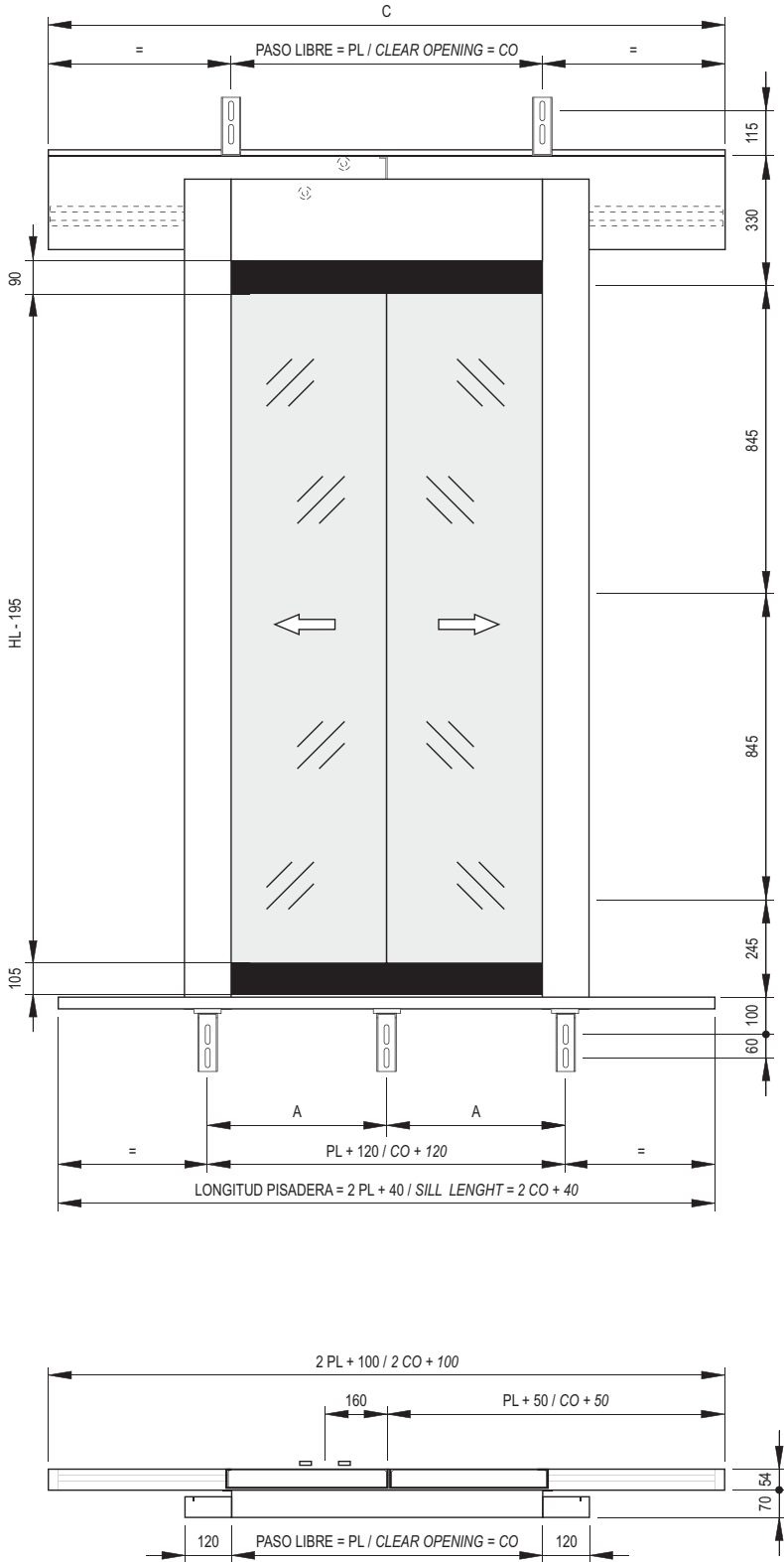

PL / CO	600	650	700	750	800	850	900	1000	1100	1200	1300	1400	1500	1600	1700	1800	1900	2000
C	1300	1400	1500	1600	1700	1800	1900	2100	2300	2500	2700	2900	3100	3300	3500	3700	3900	4100
A	360	385	410	435	460	485	340	373	407	330	355	380	324	344	303	320	337	303
S	3	3	3	3	3	3	4	4	4	5	5	5	6	6	7	7	7	8
T	5	5	5	5	5	5	6	6	6	8	8	8	9	9	10	11	11	12

S: N°. de soportes en apoyo pisadera.  
S: Number of supports for sill support.

T: N°. de soportes total.  
T: Total number of supports.

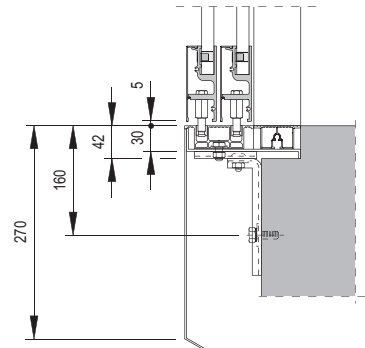
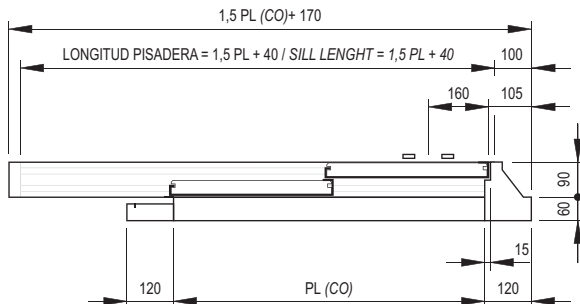
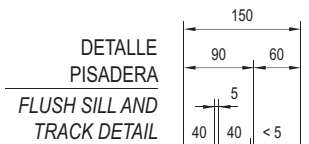
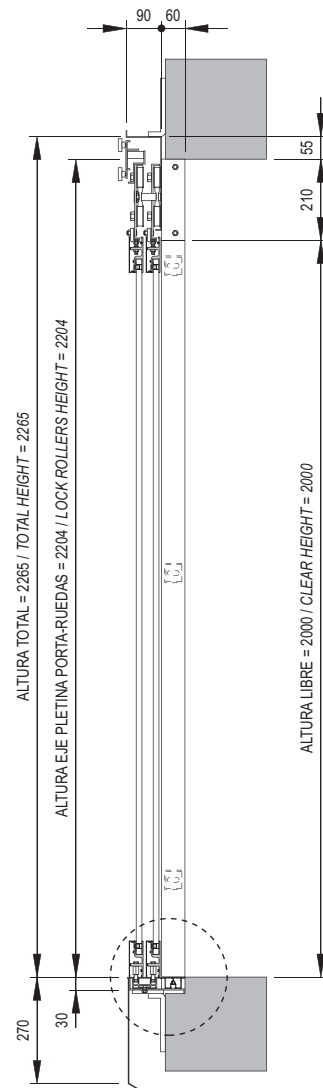
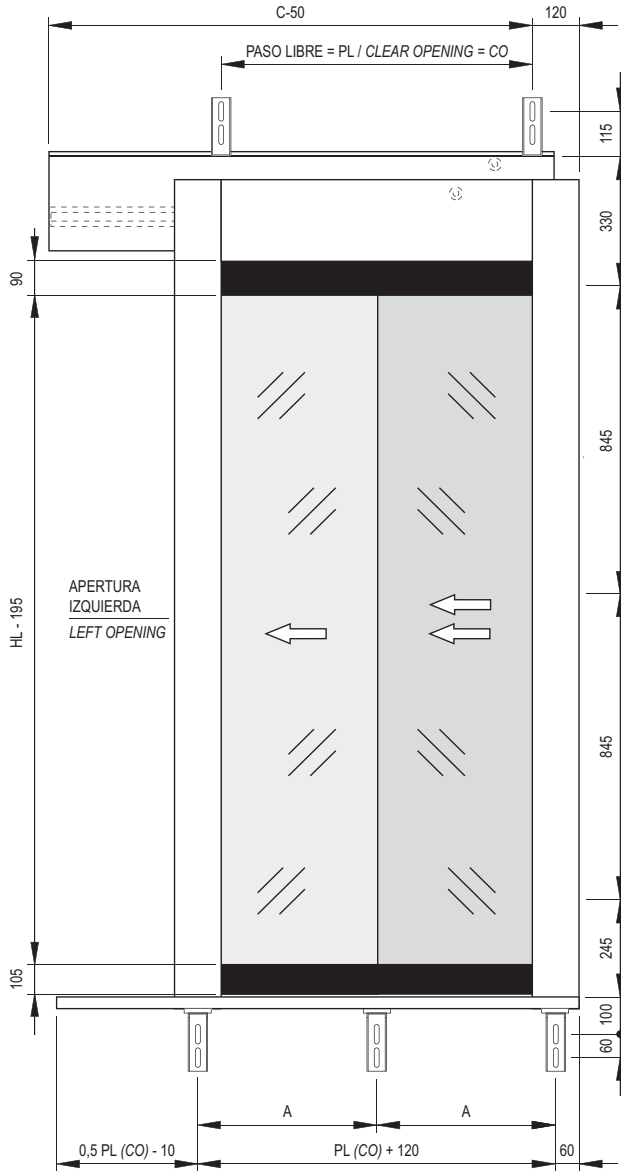

PL / CO	600	650	700	750	800	850	900	1000	1100	1200	1300	1400	1500	1600
C	1000	1075	1150	1225	1300	1375	1450	1600	1750	1900	2050	2200	2350	2500
A	360	385	410	435	460	485	340	373	407	330	355	380	324	344
S	3	3	3	3	3	3	4	4	4	5	5	5	6	6
T	5	5	5	5	5	5	6	6	6	8	8	8	9	9

S: N°. de soportes en apoyo pisadera.  
S: Number of supports for sill support.

T: N°. de soportes total.  
T: Total number of supports.

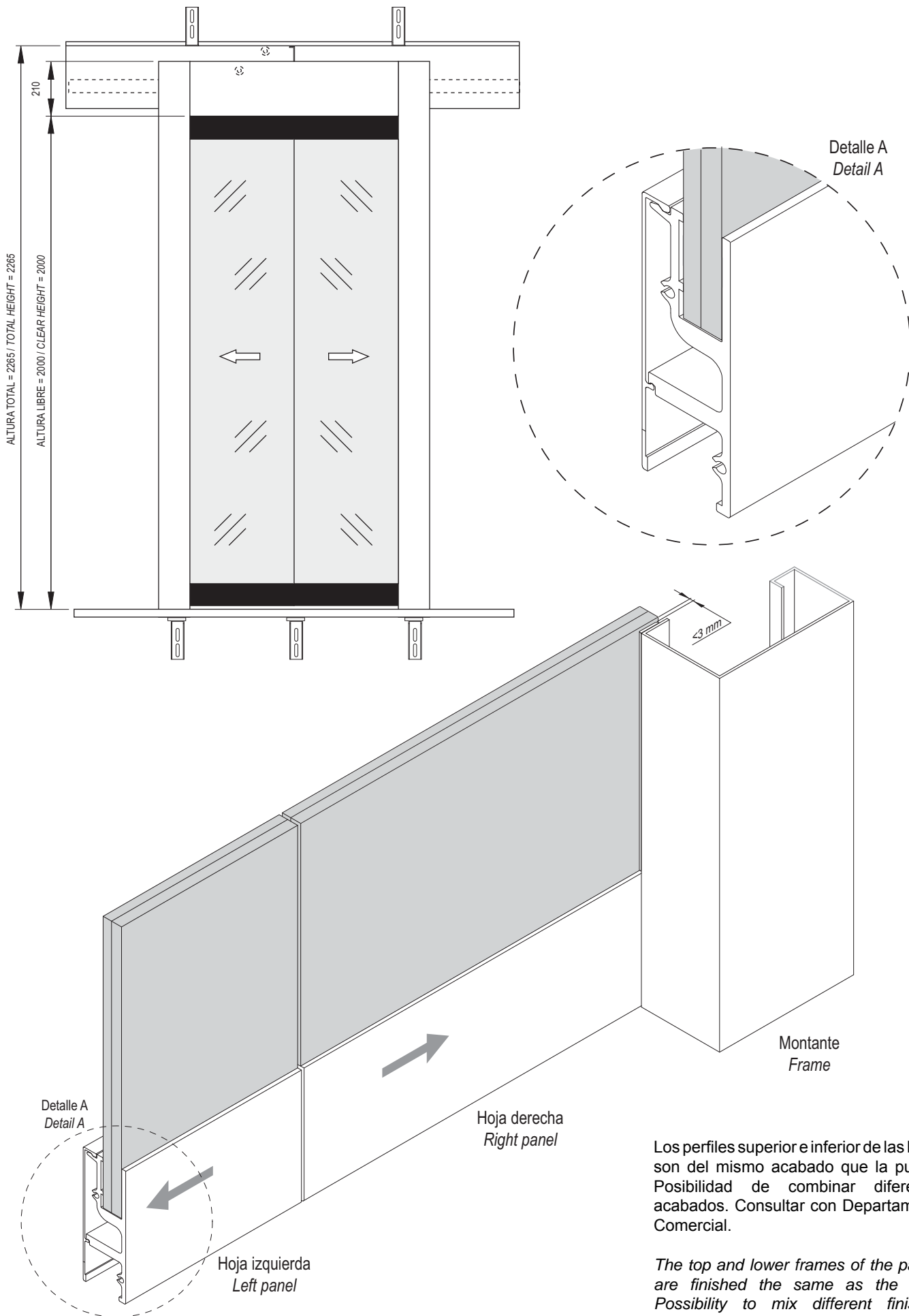

Los perfiles superior e inferior de las hojas son del mismo acabado que la puerta. Posibilidad de combinar diferentes acabados. Consultar con Departamento Comercial.

*The top and lower frames of the panels are finished the same as the door. Possibility to mix different finishes. Contact our Commercial Department.*

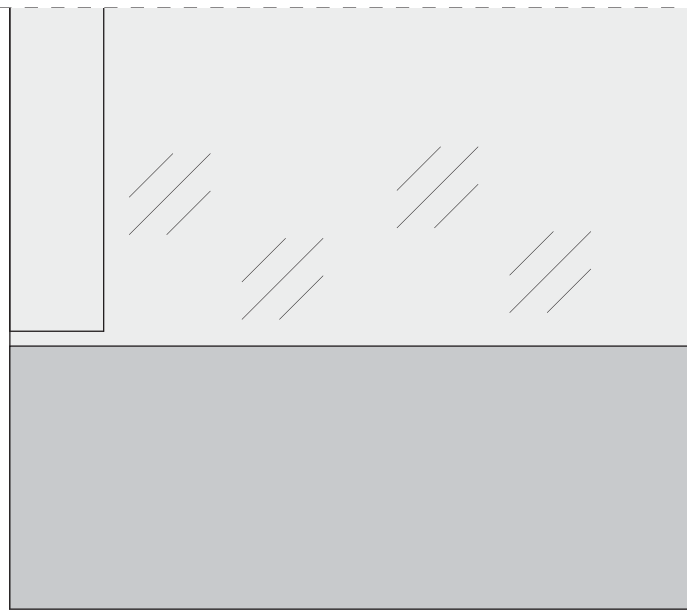
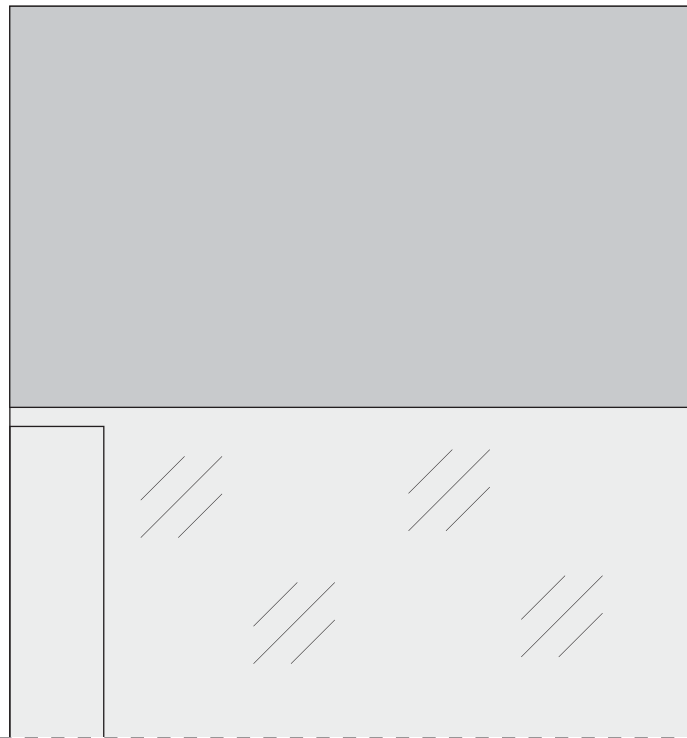

ANCHURA DE LA HOJA = E  
PANEL WIDTH = E

