

# Independence made easy

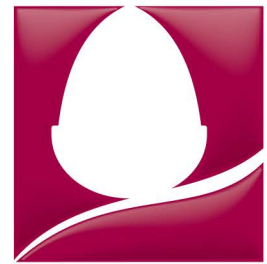

ACORN  
STAIRLIFTS

## The Acorn 180 Curved Stairlift

With the Acorn 180 Curved Stairlift, there's no longer any need to compromise your independence and struggle with the stairs in your home. You can be proud to join the thousands of people all over the world who enjoy independent living at home, thanks to the Acorn 180.

The Acorn 180 has a built-in soft start and stop facility, and you can be sure that your stairlift is always ready for use thanks to the integral rechargeable battery pack, even in the event of a mains power failure.

The Acorn 180 fits practically any curved staircase, and its slim, attractive rail fits to your stairs, so there's no damage to your home. It has been designed to include a wide variety of comfort and safety features, to provide you with many years of safe and reliable enjoyment of your stairlift. To ensure your lift is simple and effortless to operate, the Acorn 180 has also been designed with ease of use and comfort in mind.

The unique self-levelling transport system moves the stairlift along the low profile rail and automatically adjusts the speed and level of the seat when moving round corners. The stairlift's electronic programming ensures optimum performance at all times, providing a comfortable ride

When not in use, the Acorn 180 can be folded away; its slim profile and unique inside parking ability ensures that the staircase is not obstructed, allowing other members of the household to use the stairs as normal.



**Give your life a lift<sup>®</sup>**

Enjoy the home you love





## A wealth of features for your benefit

- 1 Padded seat and backrest.
- 2 Easy to use controls.
- 3 Secure safety belt.
- 4 Folding arms, footrest and seat allow easy access to the stairway.
- 5 Swivel seat - no need for twisting the body to get on and off the lift.
- 6 Diagnostic digital display informs the user of the status of the lift.
- 7 Modular rail allows the rail portion of the lift to be quickly assembled from stock components, enabling faster delivery and an installation time to suit you.
- 8 Safety sensors on the footrest and carriage stop the lift automatically if any obstruction is encountered.
- 9 Hand-held remote controls allow users to 'call' or 'send' the lift up and down the staircase.

### Dimensions

	mm	inch
A Floor to top of footrest	50	2
B Top of footrest to top of seat	485	19
C Top of seat to top of arms	245	9¾
D Top of arms to top of seat back	195	7¾
E Width between armrests	480	19
F Overall width including seatbelt	620	24½
G Overall height	975	38¾
H Length of arms from seat back	460	18
I Length of seat base from seat back	435	17
J Length of footrest	360	14¼
K Width of footrest	375	14¾
L Front of footrest to stringer	640	25¼
M Back of seat to stringer	35	1½
N Folded width	335	13¼

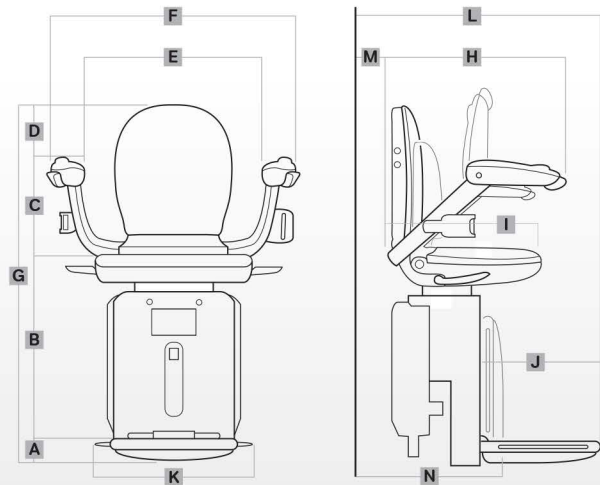

### Specifications

Motor Power	0.375KW	Maximum Capacity	120kgs
Motor Output Speed	No greater than 0.15 m/s	Track	Extruded Aluminium
Method of Drive	Rack and Pinion	Mains Supply	100/240V, 50/60Hz Charger
Power Supply	24V DC (battery)		

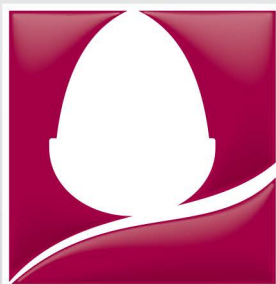

**ACORN**  
STAIRLIFTS

#### Dealer Stamp

#### Eltouny Elevators Company

3rd Industrial Area, Plot 122, 6th Of October, Giza, Egypt  
 (+2) 01000307719 | 01006600988  
[www.eltouny.net](http://www.eltouny.net)  
[eltouny@eltouny.net](mailto:eltouny@eltouny.net)



5873/ACIND/CUR1114

Acorn Mobility Services Ltd · Telecom House  
 Millennium Business Park · Station Road · Steeton · West Yorkshire · BD20 6RB  
 Acorn reserves the right to change specifications without notice. All measurements are approximate.  
 Images are shown for illustrative purposes only. Product may vary slightly.